

OWNER'S MANUAL

SPLIT DUCT TYPE AIR CONDITIONER

Thank you very much for purchasing our air conditioner,
Before using your air conditioner, please read this manual carefully and keep it for future reference.

INDOOR UNIT

OUTDOOR UNIT

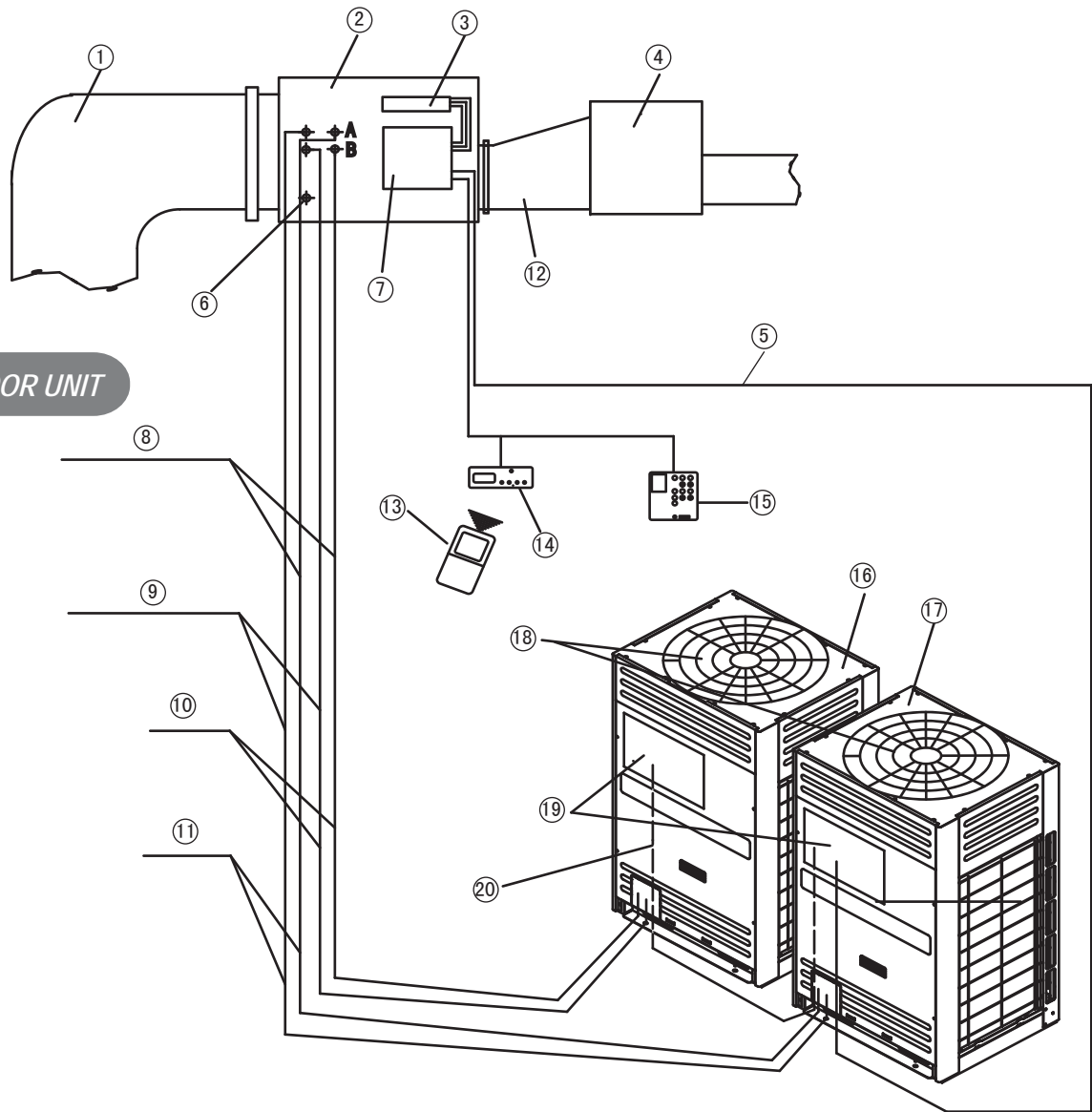

①	Return air duct (Not attached fittings, purchase at field as per your actual requires)	⑥	Drain vent	⑪	System A	⑬	Remote controller	⑯	Auxiliary outdoor unit
②	Indoor unit	⑦	Indoor unit electric control box	⑫	System B	⑭	Remote signal reciving panel	⑰	Main outdoor unit
③	Capacitance box	⑧	Refrigerant pipe(Φ12.7)	⑮	Wire controller(Optional)	⑱	Main auxiliary outdoor unit electric control box	⑲	Main auxiliary outdoor unit electric control box
④	Mute box(Not attached fittings, purchase at field as per your actual requires)	⑨	Refrigerant pipe(Φ28.6)	⑳	Connect wire between main and auxiliary outdoor units				
⑤	Connevtive wire between indoor and outdoor unit								



NOTE

All the pictures in this manual are for explanation purpose only. They may be slightly different from the air conditioner you purchased(depend on model).The actual shape shall prevail.

CONTENTS

PAGE

IMPORTANT SAFETY INFORMATION.....	1
AIR CONDITIONER OPERATIONS AND PERFORMANCE.....	2
MAINTENANCE.....	2
FOLLOWING SYMPTOMS ARE NOT AIR CONDITIONER TROUBLES.....	3
TROUBLESHOOTING.....	3
REPARATION.....	3
TECHNICAL STANDARD.....	3
APPENDIX I.....	4
APPENDIX II.....	5

1. IMPORTANT SAFETY INFORMATION

To prevent injury to the user or other people and property damage, the following instructions must be followed. Incorrect operation due to ignoring of instructions may cause harm or damage.

The safety precautions listed are divided into two categories. In either case, important safety information is listed which must be read carefully.



WARNING

Failure to observe a warning may result in death. The appliance shall be installed in accordance with national wiring regulations.



CAUTION

Failure to observe a caution may result in injury or damage to the equipment.



WARNING

Ask your dealer for installation of the air conditioner.

Incomplete installation performed by yourself may result in a water leakage, electric shock, and fire.

Ask your dealer for improvement, repair, and maintenance.

Incomplete improvement, repair, and maintenance may result in a water leakage, electric shock, and fire.

In order to avoid electric shock, fire or injury, or if you detect any abnormality such as smell of fire, turn off the power supply and call your dealer for instructions.

Never let the indoor unit or the remote controller get wet.

It may cause an electric shock or a fire.

Never press the button of the remote controller with a hard, pointed object.

The remote controller may be damaged.

Never replace a fuse with that of wrong rated current or other wires when a fuse blows out.

Use of wire or copper wire may cause the unit to break down or cause a fire.

It is not good for your health to expose your body to the air flow for a long time.

Do not insert fingers, rods or other objects into the air inlet or outlet.

When the fan is rotating at high speed, it will cause injury.

Never use a flammable spray such as hair spray, lacquer or paint near the unit.

It may cause a fire.

Never touch the air outlet or the horizontal blades while the swing flap is in operation.

Fingers may become caught or the unit may break down.

Never put any objects into the air inlet or outlet.

Objects touching the fan at high speed can be dangerous.

Never inspect or service the unit by yourself.

Ask a qualified service person to perform this work.

Do not dispose this product as unsorted municipal waste. Collection of such waste separately for special treatment is necessary.

Do not dispose of electrical appliances as unsorted municipal waste, use separate collection facilities.

Contact you local government for information regarding the connection systems available.

If electrical appliances are disposed of in landfills or dumps, hazardous substances can leak into the groundwater and get into the food chain, damaging your health and well-being.

To prevent refrigerant leak, contact your dealer.

When the system is installed and runs in a small room, it is required to keep the concentration of the refrigerant, if by any chance coming out, below the limit. Otherwise, oxygen in the room may be affected, resulting in a serious accident.

The refrigerant in the air conditioner is safe and normally does not leak.

If the refrigerant leaks in the room, contact with a fire of a burner, a heater or a cooker may result in a harmful gas.

Turn off any combustible heating devices, ventilate the room, and contact the dealer where you purchased the unit.

Do not use the air conditioner until a service person confirms that the portion where the refrigerant leaks is repaired.



CAUTION

Do not use the air conditioner for other purposes.

In order to avoid any quality deterioration, do not use the unit for cooling precision instruments, food, plants, animals or works of art.

Before cleaning, be sure to stop the operation, turn the breaker off or pull out the supply cord.

Otherwise, an electric shock and injury may result.

In order to avoid electric shock or fire, make sure that an earth leak detector is installed.

Be sure the air conditioner is grounded.

In order to avoid electric shock, make sure that the unit is grounded and that the earth wire is not connected to gas or water pipe, lightning conductor or telephone earth wire.

In order to avoid injury, do not remove the fan guard of the outdoor unit.

Do not operate the air conditioner with a wet hand.
An electric shock may happen.

Do not touch the heat exchanger fins.
These fins are sharp and could result in cutting injuries.

Do not place items which might be damaged by moisture under the indoor unit.
Condensation may form if the humidity is above 80%, the drain outlet is blocked or the filter is polluted.

After a long use, check the unit stand and fitting for damage.
If damaged, the unit may fall and result in injury.

To avoid oxygen deficiency, ventilate the room sufficiently if equipment with burner is used together with the air conditioner.

Arrange the drain hose to ensure smooth drainage.
Incomplete drainage may cause wetting of the building, furniture etc.

Never touch the internal parts of the controller.
Do not remove the front panel. Some parts inside are dangerous to touch, and a machine trouble may happen.

Never expose little children, plants or animals directly to the air flow.
Adverse influence to little children, animals and plants may result.

Do not allow a child to mount on the outdoor unit or avoid placing any object on it.
Falling or tumbling may result in injury.

Do not operate the air conditioner when using a room fumigation - type insecticide.
Failure to observe could cause the chemicals to become deposited in the unit, which could endanger the health of those who are hypersensitive to chemicals.

Do not place appliances which produce open fire in places exposed to the air flow from the unit or under the indoor unit.
It may cause incomplete combustion or deformation of the unit due to the heat.

Do not install the air conditioner at any place where flammable gas may leak out.
If the gas leaks out and stays around the air conditioner, a fire may break out.

The appliance is not intended for use by young children or infirm persons without supervision.

2. AIR CONDITIONER OPERATIONS AND PERFORMANCE

Please pay attention to the following points to ensure the operation of unit.

- Refer to the relevant section for details.
- Adjust air flow direction to avoid blowing directly to the people in the room.
- Set the temperature properly to obtain a comfort ambient. Too low or too high is not recommended. Please shelter from direct sunlight with curtain or window shutter during cooling operation.
- Please close door and window to avoid the formation of convection that may decrease cooling effect. Please use your remote controller to set the desired run-time.

- Do not put anything near the inlet or outlet to block the airflow. Otherwise, it may decrease the effect of air conditioner, or stop the unit.



CAUTION

Before longtime rest, please switch off the power and remove the batteries from remote controller. If you do not switch off the power, the power will be wasted. Preheat the unit for more than 12 hours before restart. If the air filter is blocked, it will reduce the efficiency of air conditioner. Please clean the filter every two weeks.

Table 2-1

Temperature Mode	Outdoor temperature	Room temperature
Cooling operation	-17°C ~ 43°C	≥17°C
Heating operating	-7°C ~ 24°C	≤30°C
Dry operation	17°C ~ 43°C	17°C ~ 32°C



NOTE

Malfunction may be caused if the air conditioner do not runs under the condition mentioned above.

3. MAINTENANCE



NOTE

- Maintenance work can only be done by professionals.
- The main power switch must be switch off before doing electric connection or cleaning the air filter.
- Do no use water or air with the temperature above 50℃ to clean air filter and panel.
- It is suggested to check and maintain the duct biannually. Do cleaning and disinfection work every two years.
- If the air filter is blocked, it will reduce the efficiency of air conditioner. Please clean the filter every two weeks.
- If the indoor unit is installed in the place with much dust, please clean the air filter more frequently.
- Please replace the filter in case that it is difficult to do cleaning.

■ The maintenance of outdoor unit

1. Injury may be caused by improper operation on the metal plates and coil fin with sharp blade.
2. Check the air inlet and air outlet of outdoor unit regularly to ensure that they are not blocked by filth or soot.
3. The duct and other parts of outdoor unit should be also cleaned regularly. Please contact the local dealer or Midea air conditioner after-sale service center.

■ Treatment before longtime rest

- Select FAN mode for about a half day to dry the inside of the air conditioner.
- Press ON/OFF on remote controller or wire controller, then switch off the power.
- If you do not switch off the power, the power will be wasted.
- Remove the batteries from the remote controller.
- There will be some dirt in air conditioner after a longtime use, please check and repair it besides cleaning. Contact the local dealer or Midea air conditioner after-sale service center.

■ Restart the unit after a longtime rest

- 1) Check the following points
 - Make sure that the air inlets and outlet of indoor and outdoor unit are not blocked.
 - Make sure whether the grounding wire is earthed well.
 - Check whether the condensed water is drained. (Cooling)
 - Make sure the refrigerant piping and duct are insulated well.
 - Make sure the installation base is not rusted.
- 2) startup
 - Switch on the power of outdoor unit, and then that of indoor unit.
 - Start the switch of remote controller or wire controller, then turn on the air conditioner.

4. FOLLOWING SYMPTOMS ARE NOT AIR CONDITIONER TROUBLES

Symptom 1: The system does not operate

- The air conditioner does not work immediately when pressing ON/OFF .
- If the operation indicator light is lightened, it shows that the unit is in normal state.
- The protection function works to prevent the air conditioner from being overloaded for about 3 minutes. Then the compressor will run automatically.
- If the defrosting/preheating indicator light is lightened, it is in heating mode. When starting the unit, "Warm air control" will be activated because of the low temp.

Symptom 2: Mist of chilled air on air outlet

- Cooling in a room with high relative humidity (the place with much oil or dust). The room temperature will be uneven if the inside of indoor unit is dirty. Cleaning is necessary. Please consult the local dealer or Midea air conditioner after-sale service center for details. The cleaning must be done by professionals.
- If the mode shifts from defrosting to heating, the vapor will be expelled.

Symptom 3: Noise

- A continuous low sound "hiss" can be heard while the air conditioner is working, which is caused by refrigerant flowing between indoor unit and outdoor unit.
The sound "hiss" exists during the timer of defrosting or a short period after you turn off the unit, which is caused by refrigerant that stops flowing or changes its flow volume.

Symptom 4: Dust is blown from air outlet

- This occurs only in the first operation after a longtime rest.

Symptom 5: Bad odor comes from indoor unit

- This is because the indoor unit gives off the smell which comes from the wall, furniture or smoking.

Symptom 6: The mode shifts from COOL to FAN.

- To prevent the heat exchanger from frosting, the air conditioner will shift to FAN mode automatically and it will return to COOL later.
- When the room temperature decreases to the set temperature, the air conditioner will turn off the compressor automatically and shift the mode to FAN; the compressor will restart when the temperature returns. In heating mode, the operation of compressor is reversed to that mentioned above.

5. TROUBLESHOOTING

8.1 If any abnormality following occurs, please turn off the unit and switch off the power immediately. Then contact the local Midea after-sale service center.

- The working indicator light flashes rapidly (Twice per second). Switch off the power then switch it on again, the light still flashes rapidly.
- Remote controller is invalid or ON/OFF operation is abnormal.
- The fuse is melted frequently or the circuit breaks frequently.
- Some substance or water goes into the air conditioner.
- Water leakage occurs in indoor unit.
- Other abnormalities occur.

Please see **APPENDIX I and II** for troubleshooting.

6. REPARATION

If any abnormality occurs, please turn off the unit and switch off the power immediately.

Contact our dealer, particularize the model, operation condition and failure. Reparation must be done by professionals.

7. TECHNICAL STANDARD

1. This air conditioner accords with GB4706.32-2004 Safety standards for unitary air conditioner and GB/T 18836-2002.
2. The worst working condition
The working condition for max heating capacity specified in GB/T 18836-2002.
3. Noise level
Noise level is tested in half-anechoic room before delivery, which is above the national standard GB/T18836-2002.

APPENDIX I Besides the troubles mentioned above, please check the following points. If necessary, contact the after-sale service center.

Symptoms	Causes	Solution
Unit does not start	<ul style="list-style-type: none"> • Power failure. • Power switch is off. • Fuse of power switch may have burned. • Batteries of remote controller exhausted or other problem of controller. 	<ul style="list-style-type: none"> • Wait for the comeback of power. • Switch on the power. • Replace the fuse. • Replace the batteries or check the controller.
Air flowing normally but completely can't cooling	<ul style="list-style-type: none"> • Temperature is not set correctly. • Be in 3 minutes protection of compressor. 	<ul style="list-style-type: none"> • Set the temperature properly. • Wait.
Units start or stop frequently	<ul style="list-style-type: none"> • Refrigerant is too little or too much. • Air or no concreting gas in the refrigerating circuit. • Compressor is malfunction. • Voltage is too high or too low. • System circuit is blocked. 	<ul style="list-style-type: none"> • Check leakage, and rightly recharge refrigerant. • Vacuum and recharge refrigerant. • Maintenance or change compressor. • Install manostat. • Find reasons and solution.
Low cooling effect	<ul style="list-style-type: none"> • Outdoor unit and indoor unit heat exchanger is dirty. • The air filter is dirty. • Inlet/outlet of indoor/outdoor units is blocked. • Doors and windows are open • Sunlight directly shine. • Too much heat resource. • Outdoor temp. is too high. • Leakage of refrigerant or lack of refrigerant. 	<ul style="list-style-type: none"> • Clean the heat exchanger. • Clean the air filter. • Eliminate all dirties and make air smooth. • Close doors and windows. • Make curtains in order to shelter from sunshine. • Reduce heat source. • AC cooling capacity reduces (normal). • Check leakage and rightly recharge refrigerant.
Low heating effect	<ul style="list-style-type: none"> • Outdoor temperature is lower than 7°C . • Doors and windows not completely closed. • Leakage of refrigerant or lack of refrigerant. 	<ul style="list-style-type: none"> • Use heating device. • Close doors and windows. • Check leakage and rightly recharge refrigerant.

APPENDIX II Please check the following points before you ask for reparation or maintenance.

The function of conversion can not be set.		
Symptom	Checking points	Causes
The fan speed can not be changed.	Check whether the MODE indicated on the display is "AUTO" .	In AUTO mode, the fan speed of indoor unit will be shifted to "AUTO" automatically.
	Check whether the MODE indicated on the display is "DRY"	In DRY mode, the fan speed will be shifted to "AUTO" automatically. The fan speed can only be selected in modes COOL, HEAT and FAN.
The transmission indicator ▲ do not flash.		
Symptom	Checking points	Causes
Remote control signal can not be transmitted when pressing ON/OFF	Check whether the batteries in the remote controller are exhausted.	Without power supply, the remote control signal can not be transmitted.
The TEMP. Indicator is not lightened.		
Symptom	Checking points	Causes
The TEMP. Indicator is not lightened.	Check whether the MODE indicated on the display is "FAN" .	In FAN mode, temperature can not be set.
The display goes off.		
Symptom	Checking points	Causes
ON/OFF on display goes off.	Check whether the timer operation has come to an end.	The air conditioner will stop since the time set has passed.
TIMER ON goes off after a period of time.	Check whether the timer operation has come to an end.	When it is the time being set to start, the air conditioner will start automatically and the corresponding indicator will go off.
No sound indicating the receipt of signal		
Symptom	Checking points	Causes
When pressing ON/OFF , no sound from indoor unit indicating the receipt of signal.	Check whether the signal transmitter of the remote controller aims at the receiver of the indoor unit. Check whether the power supply of air conditioner has been switched on.	Aim the transmitter of remote controller at the receiver of indoor unit, then press ON/OFF repeatedly. The air conditioner can not receive the remote control signal if it is off.
Remote controller does not work.	Check the display screen of remote controller.	The buttons are locked.

MDV2023355

123456789